



3MEN TECHNOLOGY CO., LTD

4F-3, NO.2, Jian-8th Rd., Jhung-He Dist,
New Taipei City 235, Taiwan.

TEL: 886-2-82272199
www.3men.com.tw

FAX: 886-2-82272088

Stepping Motor 2T9 Series

DIMENSION (UNIT:mm)

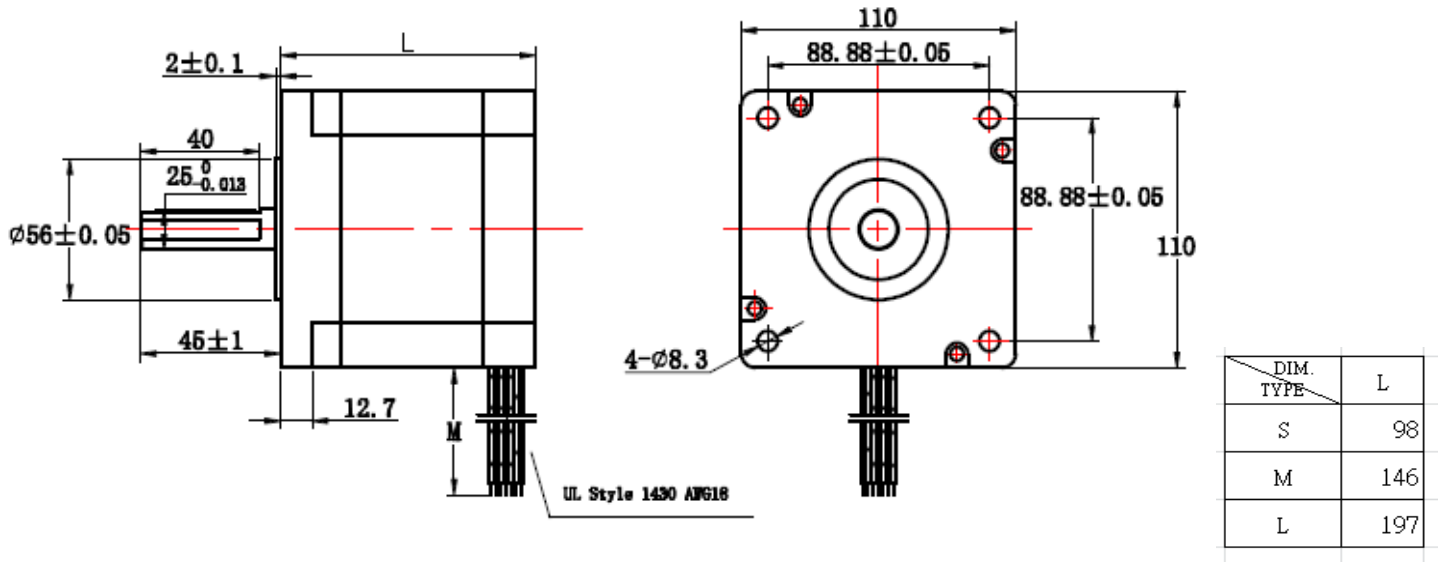

Specifications

Model	Holding Torque Kg-cm	Rated Current A/Phase	Voltage Volt.	Winding Resistance Ω/Phase	Inductance mH/Phase	Roter Inertia g-cm ²	Weight g	Length mm	Leads
2T911-630	78.00	3.00	12.60	4.20	23.00	6000	5100	98	6
2T911-440	110.00	4.00	9.40	2.35	18.00	6000	5100	98	4
2T921-630	150.00	3.00	19.20	6.40	47.00	12100	8400	146	6
2T921-440	210.00	4.00	8.80	2.20	38.00	12100	8400	146	4
2T921-460	240.00	6.00	9.00	1.50	23.00	12100	8400	146	4
2T931-630	210.00	3.00	26.40	8.80	69.00	18200	11500	197	6